



HGMini

Description of the hygrostat

The humidity measuring element which is manufactured by Galltec under the name "Polyga", consists of several plastic fabric bands each with 90 individual fibres with a diameter of 0.003 mm each. The fibres are provided with hygroscopic characteristics by a special process. The measuring element absorbs and desorbs moisture. The effect, swelling predominantly in longitudinal direction, is supplied to a microswitch with an extremely low switching travel via a suitable lever system. The measuring element responds rapidly and precisely to the change in air humidity. It is possible to adjust the lever system by setting the setpoint knob so that the microswitch is actuated when the set air humidity is reached.

The hard-shaped measuring element is accommodated inside the housing and must be protected against coarse dust, dirt and water. The sensors are designed for pressureless systems. The installation location must be selected so that condensed water cannot enter the inside of the housing. Any installation position is possible, preferably with ventilation slots at right-angles to wind direction.

Type Survey

Type	Item No.	switching
HG Mini	42042017	1 selector switch for humidification or dehumidification
HG Mini-i	42042018	1 selector switch for humidification or dehumidification knob inside the housing
HG Mini Schnapp	42042019	1 selector switch for humidification or dehumidification with snap-on installation

typeHGMini
typeHGMini-i
typeHGMini-Schnapp

RoomHygrostat

measuring range 30..100%rh

Application

The hygrostat type **HG Mini** is used as a two-position controller for controlling the relative air humidity in air ducts in air-conditioning systems and climatic cabinets, for controlling air humidifiers and dehumidifiers and for dehumidification control in swimming baths. Further applications are in stores for foodstuffs, semi-luxury foods and tobacco, refrigerated rooms for fruit and vegetables, greenhouses for horticultural businesses, the textile industry, paper and printing industries, film industry and hospitals. The hygrostat HG Mini is suitable for many applications where air humidity has to be controlled or monitored.

The room hygrostat **HG Mini-i** is designed so that the control knob is inside the housing. This makes unauthorized by third parties more difficult.

The room hygrostat **HG Mini Schnapp** is additionally equipped with an adapter plate which permits snap-on installation on a 35 mm top-hat rail in accordance with DIN 43604.

Technical Data

measuring range 30...100%rh
measuring accuracy ±3,0%rh
working range 35...100%rh
switching difference (microswitch) ref. to 50%rh ... 4%rh approx.
max voltage 250 V AC

!!Attention: 250 V only if it is ensured that no condensate can form in the sensor head, because voltage flashover must otherwise be expected.

breaking capacity, maximum load

ohmic load5A 230V AC (lifetime 10,000 cycles)
max load "humidify" 2A
"dehumidify" 5A
inductive load cos φ = 0.8 0.2A 230V AC
inductive load* L/R=3ms 1A to 50V DC
.....0.5 to 75V DC
electric bulb load.....0.2A to 50V DC

breaking capacity, **minimum load**.....100mA, 20VDC / AC
allowable ambient temperature 0...60°C
medium temp. coefficient-0,2%/K relative to 20°C and 50%rh
allowable air speed 15m/sec
t₀₅ at v=2m/sec 1.2min
fixing.....slots in housing base
mounting position preferably ventilation slots at right-angles to wind direction

contacting connecting terminal in the case
electromagnetic compatibility EMC

immunity ref. EN 50 082-2
emission ref. EN 50 081-2

case solid plastic, light grey
dimension85 x 55 x 36mm
protective system IP20
weight ca 0,06 kg
"reserve of technical modifications"

*check for suitability!

This information is based on current knowledge and is intended to provide details of our products and their possible applications. It does not, therefore, act as a guarantee of specific properties of the products described or of their suitability for a particular application. It is our experience that the equipment may be used across a broad spectrum of applications under the most varied conditions and loads. We cannot appraise every individual case. Purchasers and/or users are responsible for checking the equipment for suitability for any particular application. Any existing industrial rights of protection must be observed. The perfect quality of our products is guaranteed under our General Conditions of Sale.
Issue: Dec. 2001 HGMINI_E. This issue supersedes all previous technical leaflets.

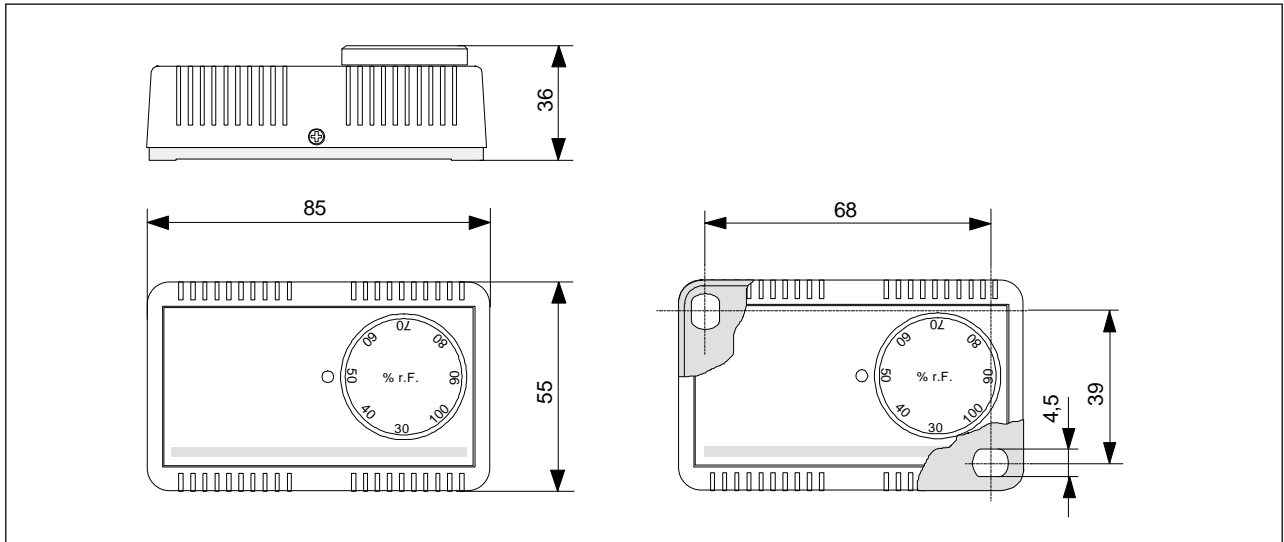

Circuit diagram

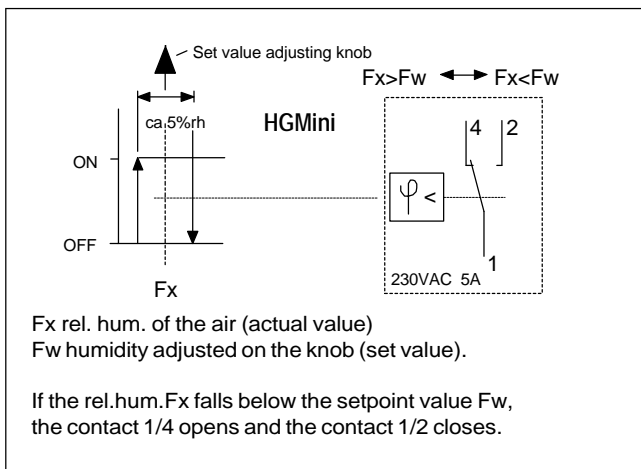

Mounting

- > The hygrostat must not be exposed to any direct water contact, e.g. splash water when cleaning the air-conditioned room etc.
- > The place of installation must be selected so that a representative air humidity measurement is guaranteed, i.e. the measured humidity values at the place of installation should correspond to those of the room as far as possible.
- > If possible, the hygrostat should be located in the air flow.

The measurement location of the humidity controller should be selected such that there is no build-up of condensate on or in the device. This applies particularly for operation with a voltage higher than 48V. If the voltage is higher, there is a risk of voltage arcing in the event of water condensation on the microswitch or connecting terminals which might destroy the controller. In the case of voltage below 48V, the humidity controller can be used up to 100%RH. The humidity controller should not be used in aggressive media.

Maintenance

In case of clean air the measuring element is maintenance-free. But aggressive and solvent containing agents as per their type and concentration may cause faulty measurements. Water repellent protective film forming deposits on the sensor, like resin aerosols, lacquer aerosols, fumigant substances etc. are harmful to almost all types of humidity sensors.

ATTENTION: No warranty will be guaranteed when inner parts of the device have been handled.

Influence of the relative air humidity

for a temperature fluctuation of ±1°C referred to various room temperatures.

	10°C	20°C	30°C	50°C
10%rh	±0,7%rh	±0,6%rh	±0,6%rh	±0,5%rh
50%rh	±3,5%rh	±3,2%rh	±3,0%rh	±2,6%rh
90%rh	±6,3%rh	±5,7%rh	±5,4%rh	±4,6%rh

It is thus of extreme importance that the temperature is constant for measurements of the relative air humidity. The air must be homogenous, e.g. possess constant humidity and temperature for the whole duration of the measurement.